

600-700 Series Low Profile

- Low Profile—Above Rail
- Locking Paddle Handles
- Sturdy Aluminum Construction
- Strong Molded Plastic Tray
- Gas Shocks for Lids



More Great Features

- 3" Deeper than Standard 600 Series
- The 700 Series is X-Tra Deep
- "J" Hook Mounting System
- Built In Compartments
- Built In Hand Tool Holder



Standard Low Profile Crossovers

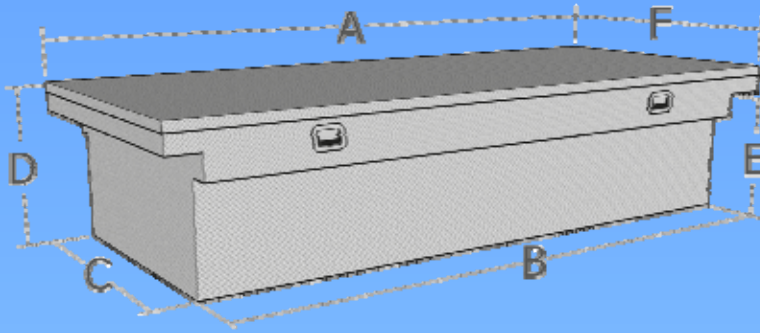

Part #	Description	A	B	C	D	E	F	UPS	Weight
TB600LP	Full Size Trucks	69 ½"	60"	17"	14 ½"	11 ½"	20 ½"	N	50
TB605LP	'99-C Ford Super Duty, '04-C Ford F150 '03-C Dodge Ram	73 ½"	62"	17"	14 ½"	11 ½"	20 ½"	N	54
TB610LP	'01-C Explorer Sport Trac '83-'93 S10/All Ranger/ LWB Imports	59"	51"	17"	14 ½"	11 ½"	20 ½"	N	45
TB620LP	S/B Import w/ notch	59"	51"	17"	14 ½"	11 ½"	20 ½"	N	45
TB621LP	'99-C Nissan Frontier Crew Cab w/ notch	59"	51"	17"	14 ½"	11 ½"	20 ½"	N	45
TB630LP	'04 Chevy Colorado, '06 Nissan Titan '94-C S10/S15 All Dodge Dakota, 06-C Tacoma	61 ½"	53 ½"	17"	14 ½"	11 ½"	20 ½"	N	47
TB640LP	S10 & Full size Sport sides/ '96 Flair side	55"	47"	17"	14 ½"	11 ½"	20 ½"	N	42
TB650LP	Ford Ranger Splash Step-Side	50"	42"	17"	14 ½"	11 ½"	20 ½"	Y*	39
TB657LP	'02-C Chevy Full Size Composite Bed	69 ½"	57"	17"	14 ½"	11 ½"	20 ½"	N	50
TB660LP	'01-C F150 Super Crew Toyota T-100/'97-C Flair side	66"	56 ½"	17"	14 ½"	11 ½"	20 ½"	N	49
TB661LP	'99-C Toyota Tundra & Access cab & Step side	67 ½"	59 ½"	17"	14 ½"	11 ½"	20 ½"	N	49
TB662LP	'01-C Toyota Tacoma Step side	52"	44"	17"	14 ½"	11 ½"	20 ½"	Y*	41
TB680LP	'04-C Chevy Colorado Crew Cab, '06 Nissan Front. '02 Chevy S10 (4 door crew cab) 01-05 Tacoma & Tacoma Crew Cab w/notch	60"	52"	17"	14 ½"	11 ½"	20 ½"	N	47
TB700LP	Full Size Trucks (X-deep)	69 ½"	60"	17"	18 ½"	15 ½"	20 ½"	N	55
TB705LP	'99-C Ford Super Duty, '04 Ford F-150, '03-C Dodge Ram (X-deep)	73 ½"	62"	17"	18 ½"	15 ½"	20 ½"	N	59

* Ship as FedEx Oversize based on dimensional weight.

Sizes and weights are nominal
All products available with black powder coat—Add "-B" to end of part number. (eg. TB600LP-B)